

- General site proposal notes**
- Golden arch road markings to be yellow thermoplastic.  
 Drive thru related road markings to be yellow thermoplastic.  
 Accessible parking bays to be lined in yellow thermoplastic - to current Part M standards.  
 Parked order bays and numbers to be lined in yellow thermoplastic.  
 All other road markings to be white thermoplastic material unless otherwise stated.
- - - Existing elements to be removed / demolished.
  - DK Drop kerb - Adjacent to accessible parking, pedestrian crossings and along delivery routes.
  - 6m Indicative lighting column - position to be confirmed by lighting consultant.
  - Target Trash Bin  
 Combo Delta Large Aperture Litter Bin by Gladon.  
 530mm x 470mm high x 1550mm high.  
 Bin body & door: Black.
  - Cranked Bollard  
 McDonald's standard cranked bollard.  
 1200mm high, 300mm offset painted white.
  - Bollard  
 A-Safe flex heavy duty bollard 225mm OD 1200mm high or similar approved.  
 Colour Grey (RAL 9007)
  - COD  
 PPC Aluminium Speaker Post (RAL 7022 Gray) 530w x 200d x 1570mm high with white acrylic Canopy over 2390w x 3500d x 3200mm high.
  - Height Restrictor.  
 PPC black 150mm dia circular hollow section steel 'Coal Plat' height restrictor with warning bar suspended on chains. With panel above to read "Maximum Height 2.7m / 8' 10" While text on green background. O/A size = Amend to suit mm wide x 3200mm high

- Notes:**  
 All drawings to be read in conjunction with all other drawings as noted on issue sheet.
- Proposed Site Finishes:**
- Tarmacadam - Car park and footpaths as indicated.
  - Marshall's 200 x 100mm Charcoal Keyblok paving - Patio & footpaths as indicated.
  - Charcoal imprinted concrete - Drive thru lane.
  - Charcoal brushed concrete - delivery route.
  - Brushed concrete - corral floor slab. See Structural Engineers drawings for further details.
  - Safety floor. Min. 50mm thick, wet pour bonded rubber. To be confirmed by Project Manager.
  - Existing areas of soft landscaping to be retained.
  - Soft landscaping - see drawing 7707-SA-8847-007 for further details.
  - Tactile blister paving.
- External Fixtures & Fittings:**
- Aubriam - Range Euroline 3 Mix 2015 Electrogalvanised steel structure, PPC RAL 7022. Table legs made of extruded aluminium, PPC RAL 7022. Table seats & plate in 12mm HPL panel with white acrylic Canopy over 2390w x 3500d x 3200mm high.
  - 2 seat table must be fixed to the ground.
  - Ash Bin.
  - Dust Bin with "Tidy Man" Sticker.
  - Pedestrian Guarding  
 1500mm or 600mm long x 1100mm high. Timber effect galvanised steel.
  - Electricity Kiosk  
 Green Electricity Meter Housing 1600w x 800d x 2285mm High. Indicative location only. Position to be agreed with M&E Consultant after service entry positions have been established.

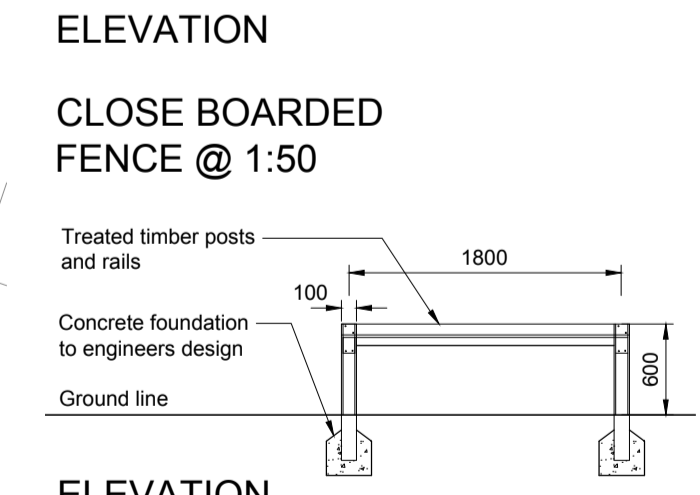
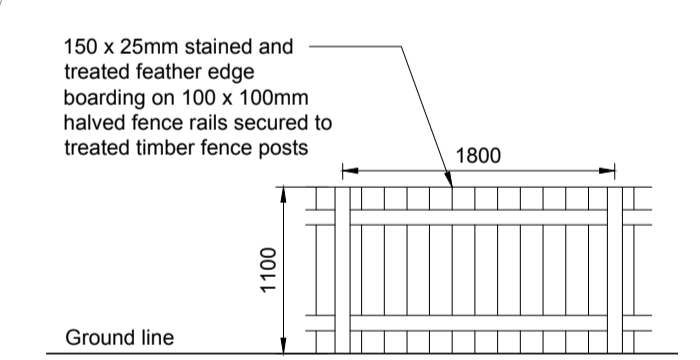
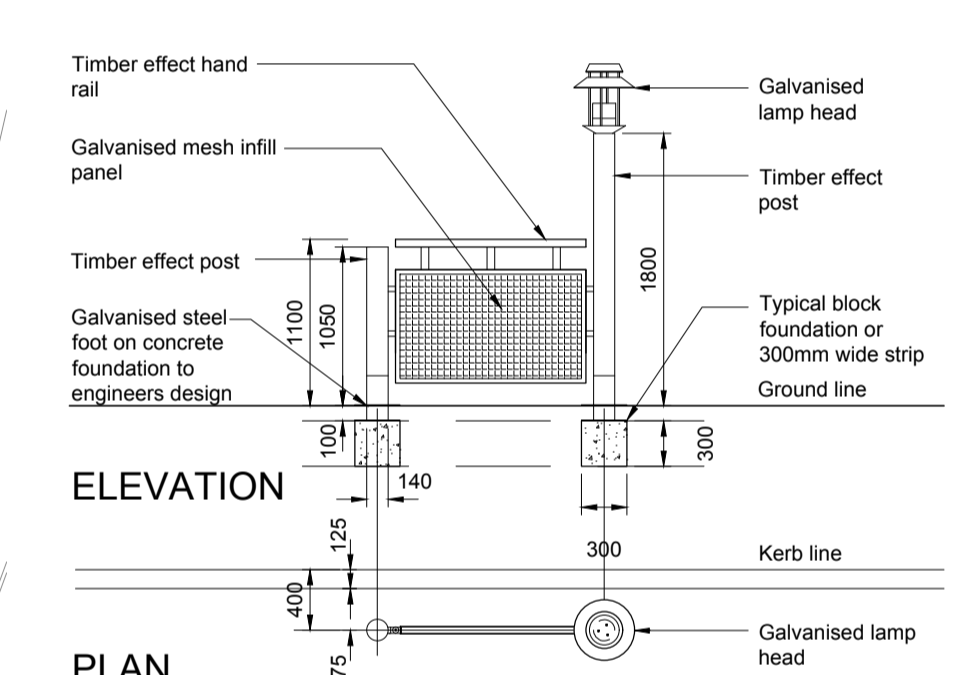

REV.	DATE	DESCRIPTION	BY	CHECKED
C	15.02.2021	Car Park Barriers omitted	RJP	
B	01.02.2021	Additional lamp posts added in accordance with developers lighting plans	RJP	
A	04.01.2021	Pedestrian Link Reinstated. Barrier removed. circulation space at entrance amended. Elec kiosk position amended.	RJP	

**GENERAL NOTES:**  
 All works are to be undertaken in accordance with the Building Regulations and the latest British Standards.  
 All proprietary materials and products are to be used ready in accordance with the manufacturer's recommendations.  
 All dimensions to be checked on site prior to construction.  
 All risks assessed to comply with the designer's responsibility under the Construction (Design Management) Regulations 2015.

PROPOSED DEVELOPMENT AT: STORE No: 11  
 Barrack Retail Park, Barrack Road NB 8847  
 CHRISTCHURCH BH23 2AW

ON BEHALF OF:   
 McDonald's Restaurants Ltd  
 DRAWING TITLE:   
 Site Layout Plan  
 As Proposed

DRAWN BY: RJP CHECKED BY:  
 SCALE & SIZE: 1:200@A1 DATE: Dec 2020

